

Workstation Equipment and Accessories



Ergonomic Tool Handling with or without Position Control



Perfectly coordinated stand and gantry solutions guide the screwdriving tool securely to the assembly position and take the strain off the operator.

Position control systems ensure that at the right place, at the right time, the correct connection element is assembled to the correct torque.

Optional Systems

For tool handling with position control	Page 3
For tool handling without position control	Page 3

The Position Control Stand / the Position Control Gantry**Page 4/5****With Position Control**

Position control stand - technical data/accessories/dimensions	Page 6/7
Position control gantry - technical data/dimensions	Page 8
Software products suitable for position control stand	Page 9
Software products suitable for position control stand and position control gantry	Page 10
Possible combinations with position control stand and position control gantry	Page 19-23

Without Position Control

Linear stand - description/technical data/accessories/dimensions	Page 11
Parallelogram stand / additional swivel-arm	Page 12
Rail-guided torque relief arm / swivel-arm for table installation/ additional swivel-arm	Page 12/13
Swivel-arm for wall installation / balancer stand / telescopic torque arm	Page 14
Screwdriver stand	Page 15

Accessories

Balancers, hose balancers, spiral hoses	Page 16
Screwdriver adapter for electric and pneumatic screwdrivers	Page 17
V-mounting bracket and more accessories (support rings, handles)	Page 18



Tool Handling with Position Control

Optional systems:

- Position control stand PKS
- Position control gantry PKP

Notes:

- Monitoring of the screw position and screw sequence, freely programmable
- Individual screw tightening parameters available for each screw position
- Takes the strain off the operator by absorbing the reaction torque
- Vertical screwdriver guidance
- Optionally with integrated vertical stroke to relieve the operator. The pressure is activated by a cylinder.

Tool Handling without Position Control

Optional systems:

- Linear stands
- Rail-guided torque relief arms
- Parallelogram stands
- Balancers

Notes:

- Takes the strain off the operator by absorbing the reaction torque
- Vertical screwdriver guidance
- Optionally with integrated vertical stroke to relieve the operator. The pressure is activated by a cylinder.

APPLICATIONS

Perfectly coordinated stand and gantry solutions guide the screwdriving tool securely to the assembly position and take the strain off the operator. Position control systems ensure that at the right place, at the right time, the correct connection element is assembled to the correct torque.

Notes

- Monitoring of the screw position and screw sequence, freely programmable
- Individual screw tightening parameters available for each screw position
- Takes the strain off the operator by absorbing the reaction torque
- Vertical screwdriver guidance
- Optionally with integrated vertical stroke to relieve the operator. The pressure is activated by a cylinder.

Functionality

The best process reliability can be achieved with the use of a position control stand/position control gantry which coordinates, optimises and controls the complete production process.

The stand/gantry can be operated with any DEPRAG screwdriving technology.

The position recognition feature increases processing reliability in applications where several screw positions need to be assembled in a certain order on one product. As soon as the position control stand/position control gantry is in the correct position screw tightening will begin. Equipped with guidance hardware and software, the stand/gantry will only allow activation of the correct function once situated in the correct position.

The position control is able to guide inputs and outputs depending on the application. This includes functions such as clamping and locking workpieces, feeding connection elements and activating measurement functions. If there are a large number of screw positions the position control stand /position control gantry can be used to determine and monitor the relevant operating mode required and the order of positions, the screw can only be tightened if the worker has kept the order in the correct sequence.

Control and Visualisation of the Position Control Stand

Advantages:

- Increased process reliability
- Control of processing steps
- Visualisation via monitor
- Integrated electronics into the base stand
- High ergonomics

The integrated electronics provide comprehensive options for control of the assembly process and contain the following components:

- 24V inputs and outputs (for PLC, toolbox and ASTxx)
- Ethernet bushing for the integrated web server
- Serial interface for fieldbus module (optional accessories)
- Connections for up to 3 position sensors
- Connection for part sensor
- Full process supervision and operator guidance with status LED in base:
 - green = OK assembly
 - red = NOT OK assembly
 - orange = Power on
 - blue = System ready "screwdriver above correct screw position"

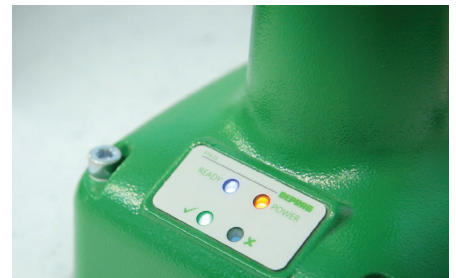

The position control stand can be used with the following operating modes:

- Stand-alone operation with a DEPRAG sequence controller
- Stand-alone operation with a DEPRAG sequence controller with toolbox
- Operation with external controller
- Operation with external fieldbus module

The operator can upload an image of the product and using program creation with “teach mode” each screwdriving position on the image can be indicated by the stand at the actual original positions. Up to 1000 screwdriving positions can be set per program whereas the number of possible programs in operation with the input and output interface is limited to 120 programs and 120 screw positions.

- Operation with MICROMAT-F/MINIMAT-F screwdriver with additional pneumatic controller pc11/pc20
- Operation with external fieldbus module (ProfiBus, ProfiNet, EtherCat, EthernetIP)

Process visualisation

If the screwdriver mounted on the stand is at the pre-set X-Y coordinate, then this is marked on screen in colour and with a text display “OK” or “NOT OK”. The lit up status LEDs on the base stand also inform the operator of the current status of the screw assembly. The web interface is used for adjustment of the processing sequences where the operator can adjust all settings as well as setting controller configurations.

Final values

After each assembly the status is stored in a csv file relating to the screw position. These values can be loaded from the position control stand via the web interface.

Control and Visualisation of the Position Control Gantry

The position control gantry controls and monitors tool positions in manual work stations.

Advantages:

- Increased processing reliability
- Control of process steps
- High degree of ergonomics due to
 - easy access and clear view of the screw positions
 - balancer used to offset screwdriver weight
 - freely accessible material supply from the rear
- High repeatability
- Extreme user-friendliness due to greatly reduced moving masses
- Large and freely accessible working area

The position control gantry functions via a processing and system controller (DCOS).

A DCOS consists of

- the control and operating unit (DPU),
- the control cabinet (DSEC) and
- standardised software modules.

Further details and technical data for the DCOS can be found in our brochure D3350E.



Our technical consultants are happy to help with your configuration.

WITH POSITION CONTROL – POSITION CONTROL STAND

Technical data – Position control stand

integrated electronics into the base stand				with analog output at the base stand				Technical data		
axes: X, Y		axes: X, Y, Z		axes: X, Y		axes: X, Y, Z				
Type	Part no.	Type	Part no.	Type	Part no.	Type	Part no.	For torque reaction up to Nm/in.lbs	Weight of horizontal arm kg/lbs	Total weight kg/lbs
PKS20	148000A	PKS20-Z	148000D	PKS20-A	148000G	PKS20-A-Z	148000J	20/177	2.2/4.84	7.85/17.3
PKS50	148000B	PKS50-Z	148000E	PKS50-A	148000H	PKS50-A-Z	148000K	50/443	7.9/17.38	32/70.4
PKS150	148000C	PKS150-Z	148000F	PKS150-A	148000I	PKS150-A-Z	148000L	150/1328	11.7/25.74	36/79.2

Required accessories for position control stand with integrated electronics into the base stand

Power supply	Type	PKS-EU	PKS-US	PKS-CN
	Part no.	102329A	102329B	102329C
Source (AC)	V/Hz	100-240 / 50/60		
Output (DC)	VDC	24		

More required accessories: balancers (see page 16) and screwdriver adapter or V-mounting bracket (see pages 17/18).

Optional equipment for position control stand

Designation	Part no.	Suitable for	Weight kg/lbs	Note
Interface fieldbus external (FBC4) Profibus	428010A	PKS types with integrated electronics		
Interface fieldbus external (FBC4) Profinet	428010B			
Interface fieldbus external (FBC4) Ethercat	428010C			
Interface fieldbus external (FBC4) EthernetIP	428010D			
Connection cable PKS ↔ fieldbus controller FBC4	101291A			
Connection cable PKS ↔ sequence controller AST11	101289A			
Connection cable PKS ↔ sequence controller AST12	101289C			
Connection cable PKS ↔ pneumatic controller pc11	101293A			
Connection cable PKS ↔ Toolbox TB7	101294A			
Connection cable PKS ↔ ComCenter ED	101289D			
External display DPUv10, size 10"	125249A		1.9	Gigabit Ethernet / 2x USB 3.0 / 2x USB 2.0 / 2x Micro HDMI Operating temperature: 0 - 50° C Voltage 12V DC
External display DPUv15, size 15"	125250A		3.8	
External display DPUv22, size 22"	126181A		6.9	
Optional: mount for external display	127460A			
DEPRAG Cockpit Advanced 1/5/10/20/50 licenses				Part no. 145795/145796/145797/145798/145799
DEPRAG Cockpit Professional 1/5/10/20/50 licenses				Part no. 145440/142967/142968/142978/142979
Ceiling support	426540A	PKS20/-Z/-A/-AZ		For better stability of the stand and increased precision the easy to install ceiling support can be attached.
Ceiling support	426540B	PKS50/-Z/-A/-AZ PKS150/-Z/-A/-AZ		
Horizontal drawback	379822O	PKS20/-Z/-A/-AZ	0.5/1.1	
Horizontal drawback	379822P	PKS50/-Z/-A/-AZ PKS150/-Z/-A/-AZ	0.5/1.1	
Clamping unit vertical	426878A	PKS20/-Z/-A/-AZ	0.4/0.88	This clamping unit is used in combination with the DEPRAG FEED MODULE (DFM). The adapted design of the clamping unit fits seamlessly with the position control stand.
Clamping unit vertical	426878B	PKS50/-Z/-A/-AZ PKS150/-Z/-A/-AZ	3.1/6.8	
Clamping unit with cylinder stroke 140mm, vertical pressure 120N at 6 bar/85psi	413144I	PKS20/-Z/-A/-AZ	1.4/3.1	For use without DFM the servo support functions in the same way as on the linear stands via clamping unit with integrated cylinder.
Clamping unit with cylinder stroke 130mm, vertical pressure 290N at 6 bar/85psi	413144J	PKS50/-Z/-A/-AZ PKS150/-Z/-A/-AZ	6.3/13.9	
Suitable pressure regulator valve	968299A	Clamping unit with cylinder		To set the cylinder power

Dimensions

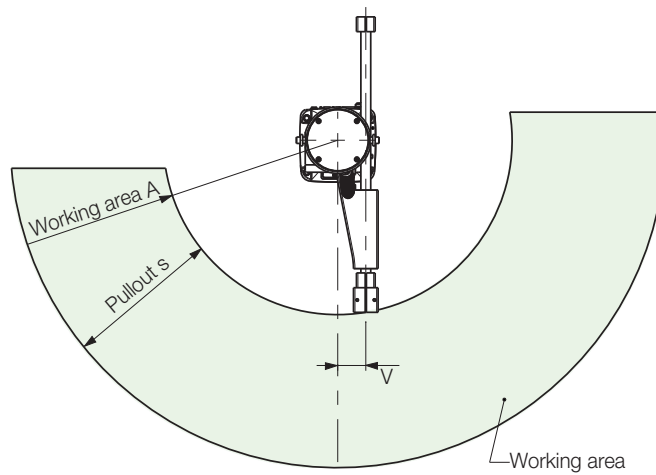
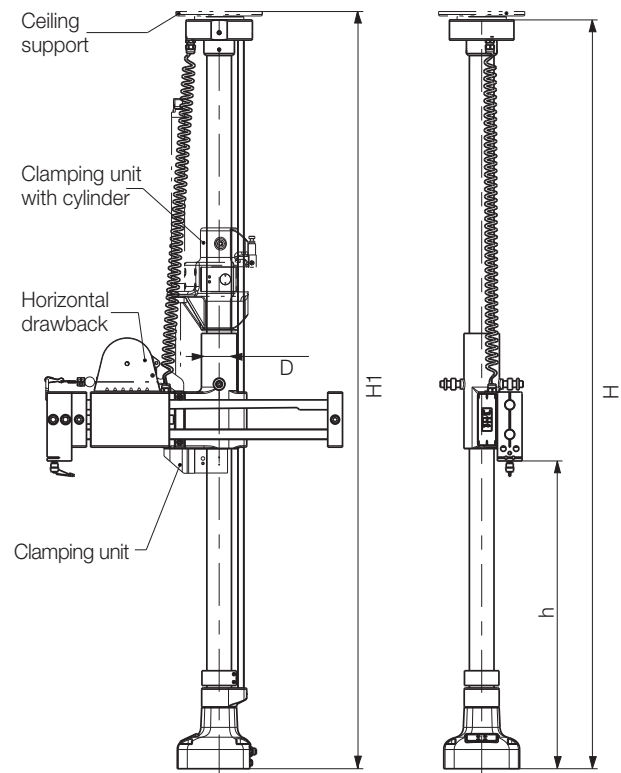

p448005

Type	Working area A mm/in.	Pullout s mm/in.	Offset V mm/in.	Column-Ø D mm/in.	Height h mm/in.	Height H mm/in.	Height H1 mm/in.
PKS20/-Z/-A/-AZ	320/12.5	235/9.2	30.5/1.2	20/0.78	137-1073/5.3-41.8	1266/49.37	1283/50
PKS50/-Z/-A/-AZ PKS150/-Z/-A/-AZ	350/13.65	313/12.2	57/2.2	50/1.95	170-1190/6.6-46.4	1521/59.32	1538/60

Technical data – Position control gantry

Position measuring system X/Y	incremental, non-contact, magnetic		
Optional: position measuring system Z	incremental, cable rope position measuring device		
Maximum travel distance (X/Y/Z) for handheld screwdrivers	mm/in.	850/740/310	/ 33.15/28.86/12.1
for DEPRAG FEED MODULE	mm/in.	710/670/310	/ 27.69/26.13/12.1
Outer dimensions (WxD) basic version	mm/in.	1100 x 1060	/ 42.9 x 41.34

The abovementioned travel distance indicates the maximum value. In practice the exact version is adjusted to your requirements. Please contact us to discuss.

Dimensions

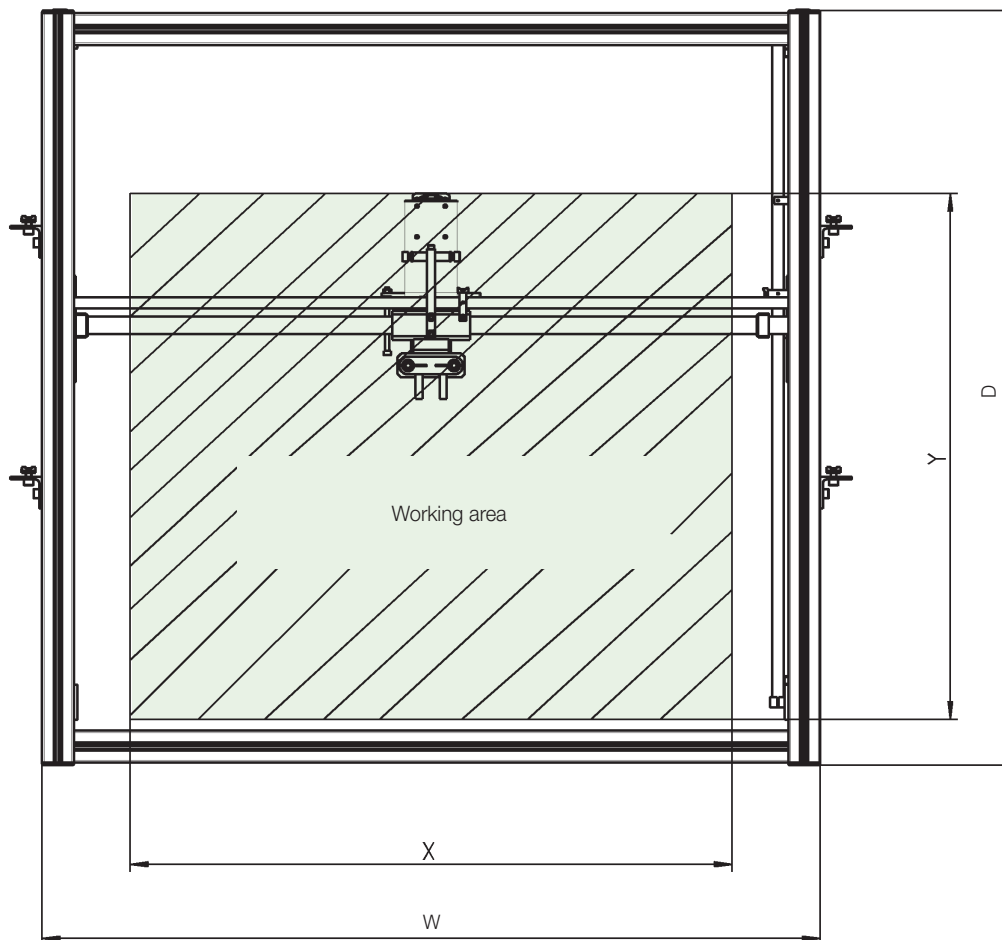

Sophisticated software products optimise and complete your DEPRAG hardware. Save costs and time whilst increasing efficiency with the intelligent, user-friendly DEPRAG software solutions.



Software products for position control stand

Software 	Description
<p>TIA Link activation key part no. 135839</p>	<p>Integration in the Siemens programming environment (Totally Integrated Automation (TIA) Portal) is required to operate DEPRAG devices with the current SIMATIC controllers. This integration is quite time-consuming and requires expert domain knowledge of the DEPRAG devices. Therefore, the software TIA link has been created to enable simple integration of the following DEPRAG products: AST11, AST12, AST40 incl. i-versions, AST 6 incl. i-versions, ComCenter 10, position control stand The software not only includes integration in the TIA portal for the above products but also several Quick-Start projects in the “structured text” programming language without first setting up communication using the user manual. The software TIA Link presents a significant time saving due to considerably reduced programming efforts. As well as the fieldbus connection, there are additional examples provided for controlling the screwdriving system. The following SIMATIC controllers are supported: SIMATIC S7-1200, SIMATIC S7-1500 and SIMATIC ET 200SP (CPU)</p>
<p>TwinCAT Link activation key part no. 140996</p>	<p>Integration in the Beckhoff programming environment is required to operate DEPRAG devices with the current Beckhoff controllers. The software TwinCAT Link has been created to enable simple integration of the following DEPRAG products: AST11, AST12, AST40 incl. i-versions, AST 6 incl. i-versions, ComCenter 10, position control stand The software not only includes integration for the above products but also several Quick-Start projects in the “structured text” programming language which enable immediate execution of screw assemblies without first setting up communication using the user manual. The Quick-Start projects are available for version TwinCAT 2 as well as version TwinCAT 3. The software TwinCAT Link presents a significant time saving due to considerably reduced programming efforts. As well as the fieldbus connection, there are additional examples provided for controlling the screwdriving system. The following Beckhoff software systems are supported: TwinCAT 2 and TwinCAT 3</p>
<p>Extended Process Control activation key part no. 162562</p>	<ul style="list-style-type: none"> - Documentation of screwdriving results and position in the PKS final value data set (screwdriving system DEPRAG Plus, AST11) - Digital operator guidance with questions and instructions - The use of several component images per sequence <p>The software download is available from the myDEPRAG customer portal (my.deprag.com) in the product catalogue under the tab Documents / Downloads. Registered users can activate the activation code and manage licences in MY ACCOUNT > DEPRAG Apps.</p>
<p>Industry 4.0 interfaces activation key part no. 162558</p>	<p>REST: interface for communication (M2M) WebSocket: interface for communication (M2M)</p> <p>The software is already pre-installed on your hardware (e.g. sequence controller, position control stand). Registered users can activate the activation code and manage licences in MY ACCOUNT > DEPRAG Apps.</p>
<p>Safety & Change tracking activation key part no. 162560</p>	<p>Process reliability and traceability – Ensure your process is secure! With this software, you can track who has changed what and when. Any unauthorised changes to the processing parameters can quickly be traced. The software is already pre-installed on your hardware (e.g. sequence controller, position control stand). Registered users can activate the activation code and manage licences in MY ACCOUNT > DEPRAG Apps.</p>
<p>Scanner activation key part no. 162561</p>	<ul style="list-style-type: none"> - Sequence selection using a scanned code - Automatic matching of processing data with the scanned code <p>The software is already pre-installed on your hardware (e.g. sequence controller, position control stand). Registered users can activate the activation code and manage licences in MY ACCOUNT > DEPRAG Apps.</p>
<p>Update PKS activation key part no. 162557</p>	<p>You receive the latest security updates, extended functions and drivers. By keeping your software version up-to-date, you can ensure that your device is optimally prepared and protected for all the innovations relating to Industry 4.0. The software download is available from the myDEPRAG customer portal (my.deprag.com) in the product catalogue under the tab Documents / Downloads. Registered users can activate the activation code and manage licences in MY ACCOUNT > DEPRAG Apps.</p>
<p>PKS Simulation activation key part no. 167387</p>	<p>The PKS simulation software enables operation, configuration and set-up without a hardware component. This means that it is possible to create and test sequences and simulate functions in the development and process planning stages. The PKS simulation software is available for Windows operating systems from Windows 10 and requires activation. The software download is available from the myDEPRAG customer portal (my.deprag.com) in the product catalogue under the tab Documents / Downloads. Registered users can activate the activation code and manage licences in MY ACCOUNT > DEPRAG Apps.</p>
<p>DEPRAG Cockpit</p>	<p>Advanced and Professional → For more details, please see brochures D3900E and D3000E.</p>

Our software solutions undergo continuous improvements. We recommend that you regularly update your software. In this way you will always receive the most up-to-date security updates, upgraded features and drivers. With the most current version of the software you can be sure that your device is optimally prepared for Industry 4.0. **The order number for the update of the position control stand is: 119657.**

For more details to the software products, please see brochure D3900E.

Optional software modules for position control stand and for position control gantry when using the DEPRAG controller system DCOS

<p>DVIP50 part no. 815629 DVIP100 part no. 815630 DVIP200 part no. 815631</p> 	<p>DVIP – DEPRAG Vision and Position</p> <p>The extension package DVIP is required if positioning control is needed for a position control stand/portal or actions should be initiated via the screwdriving position (e.g. allocation of various tools via toolbox, etc.). The package is not available for the DPU010(C).</p> <p>Application examples Position stand, position gantry, XYZ screwdriving systems (DCAM)</p> <ul style="list-style-type: none"> - Position controlled parameter selection - Position controlled tightening sequence - Product and process visualisation
<p>DAST100 part no. 815641</p> <p>DAST200 part no. 815642</p> 	<p>DAST – DEPRAG AblaufSTeuerung</p> <p>The extension package DAST is the software panel for EC and EC-Servo systems. DAST is used to supervise the operation and visualisation of the screwdriver sequence controller through the system control.</p> <p>Application examples</p> <ul style="list-style-type: none"> AST data processing AST data analysis AST data display
<p>DCON activation key part no. 136244</p> 	<p>DCON – DEPRAG Connect</p> <p>DEPRAG Connect is the software for PLC programmers who program using Beckhoff TwinCAT and DEPRAG end devices. The software product provides a simple, fast connection of DEPRAG devices in the programming environment. Time-consuming and error-prone individual programming and parameterisation is a thing of the past.</p> <p>The software is already installed on your hardware (e.g. sequence controller, position control stand). Registered users can activate the activation code and manage licences on the myDEPRAG customer portal (my.deprag.com) in MY ACCOUNT > DEPRAG Apps.</p>

Our software solutions undergo continuous improvements. We recommend that you regularly update your software. In this way you will always receive the most up-to-date security updates, upgraded features and drivers. With the most current version of the software you can be sure that your device is optimally prepared for Industry 4.0. **The order number for the update of the position control stand is: 119657.**

For more details to the software products, please see brochure D3900E.

Linear stand – for ergonomic and process reliable tool guidance

Advantages:

- user friendly
- ergonomic
- support of the tool weight
- fast and secure positioning

DEPRAG linear stand for ergonomic process reliable guidance of your tool, used to support the tool weight and for fast and secure positioning.

Please contact us if you require a special linear stand for e.g. ceiling suspension, with longer extension or with locking mechanism.

Technical data – Linear stand

For torque reaction up to Nm / in.lbs	Working area A mm/in.	Pullout s mm/in.	Grid dimension R mm/in.	Column-Ø D mm/in.	Height h mm/in.	Height H mm/in.	Weight of horizontal arm kg/lbs	Part no.
for screwdriver, straight								
20 / 177	217-329 / 8.5-12.8	242 / 9.4	28 / 1.1	20 / 0.78	115-1082 / 4.5-42.2		2 / 4.4	408010A
50 / 443	222-348 / 8.6-13.6	342 / 13.3	42 / 1.6	30 / 1.17	185-1014 / 7.2-39.5	1220 / 47.58	6.7 / 14.7	408010B
150 / 1328	279-383 / 10.9-14.9	324 / 12.6	52 / 2.0	50 / 1.95	194 - 983 / 7.6-38.3		13.7 / 30.1	408010C
for ESD screwdriver, straight								
20 / 177	217-329 / 8.5-12.8	242 / 9.4	28 / 1.1	20 / 0.78	135-1102 / 5.3-43	1240 / 48.36	2 / 4.4	408010D
50 / 443	222-348 / 8.6-13.6	342 / 13.3	42 / 1.6	30 / 1.17	205-1034 / 8 -40.3		6.7 / 14.7	408010F

Required accessories: balancers (see page 16) and screwdriver adapter or V-mounting bracket (see pages 17/18).

Optional equipment for linear stand

Designation	Part no.	Suitable for	Weight kg/lbs	Note
Horizontal draw back	379822N	Linear stand no. 408010A	0.5 / 1.1	
Horizontal draw back	379822L	Linear stand no. 408010B	1 / 2.2	
Horizontal draw back	379822M	Linear stand no. 408010C	1 / 2.2	
Clamping unit with cylinder incl. start button	on request	Linear stands		takes up the contact pressure of the screwdriver and relieves the operator
Clamping unit vertical	on request	Linear stands		the clamping unit is only used in combination with the DEPRAG FEED MODULE (DFM) or the ERGOMAT-Z screwdriver

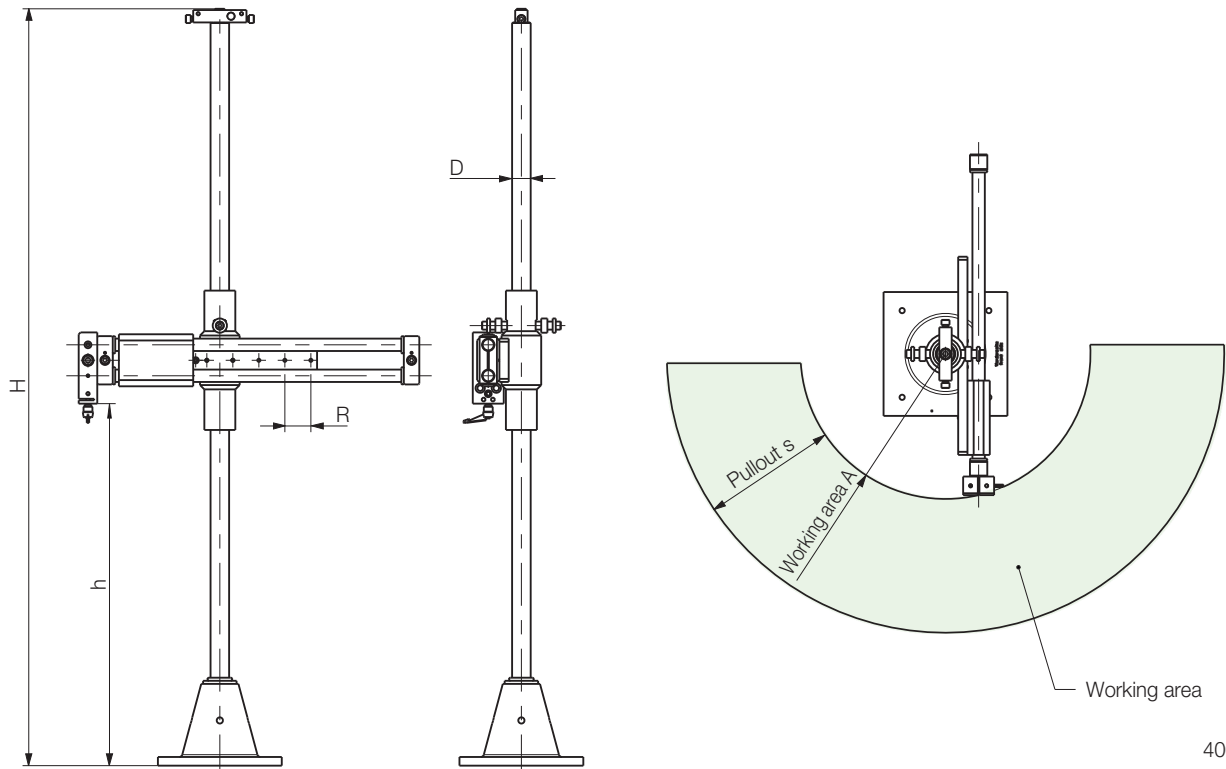

4002971

Please consider both the weight of the horizontal arm and of the screwdriver in order to select the appropriate balancer. We highly recommend the use of two balancers to spread the total weight more evenly. We recommend the use of linear stand 408010B for tools with total length ≥ 450 mm and for screwdrivers size 2 in conjunction with our feeding systems.

Parallelogram stand - for screwdriver, straight

for torque reaction up to Nm/in.lbs	Capacity kg/lbs	Working area mm/in.	Height max. mm/in.	Part no.
45 / 400	0-2 / 0-4.4	150-610/5.85-23.8	600 / 23.4	406253A

Required accessories: Screwdriver adapter or V-mounting bracket (page 17/18).
 Parallelogram stand with adjustable starting position, spring loaded.

Additional swivel-arm - for parallelogram stand 406253A

Working area mm/in.	Part no.
250 / 9.75	347607
400 / 15.6	811733A

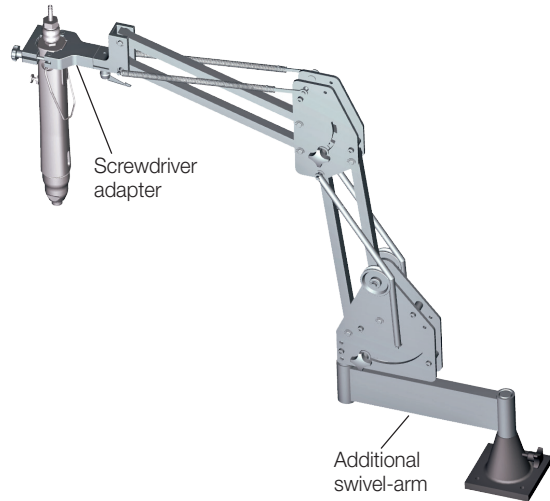

Rail-guided torque relief arm

maximum torque 20 Nm - for screwdriver in straight version and pistolgrip

Designation	Part no.	consisting of position
Parallelogram arm consisting of: parallelogram arm, guide carriage, lateral stop and elevation stop (our recommendation as minimum standard equipment)	809926A	2/3/4/9
Required accessories for this:		
Guide rail, length 1 m / 2 m / 3 m	8099151/8099152/8099153	5
End stop (is required twice)	809911	1
Optional variants and other attachments		
Parallelogram arm consisting of: parallelogram arm and guide carriage	809926B	4/9
Parallelogram arm (without attachments)	on request	9
Elevation stop	809913	3
Lateral stop (functions only in connection with elevation stop)	809912	2
Telescope holder	809907	6
Guide carriage (separate), with aluminium plate 100x100x20 mm	809910	8
Suitable screwdriver adapter	see page 17	7

Please find further information on page 12.

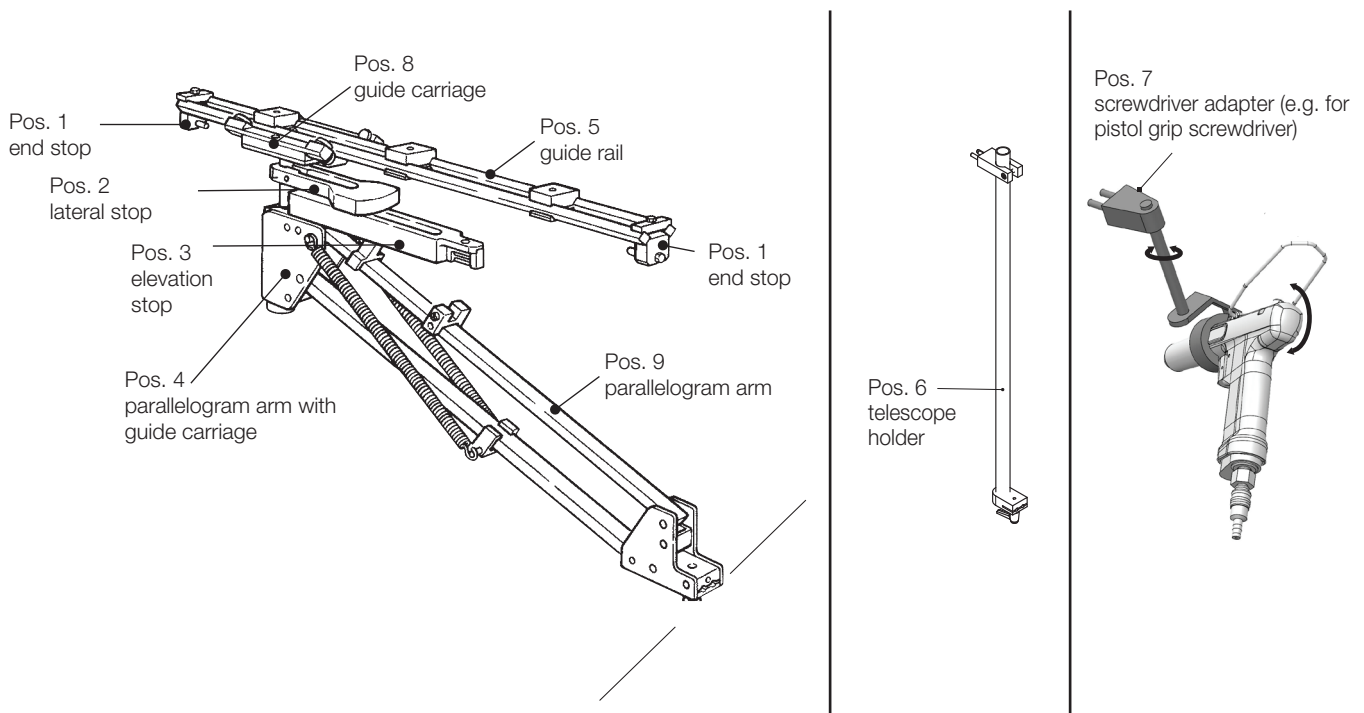

Further information about the rail-guided torque relief arm

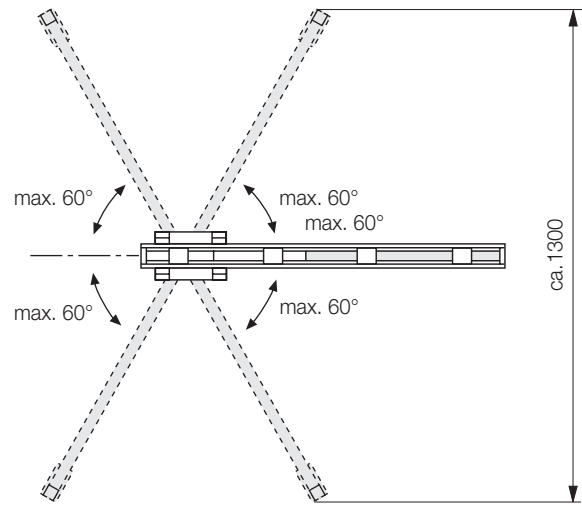
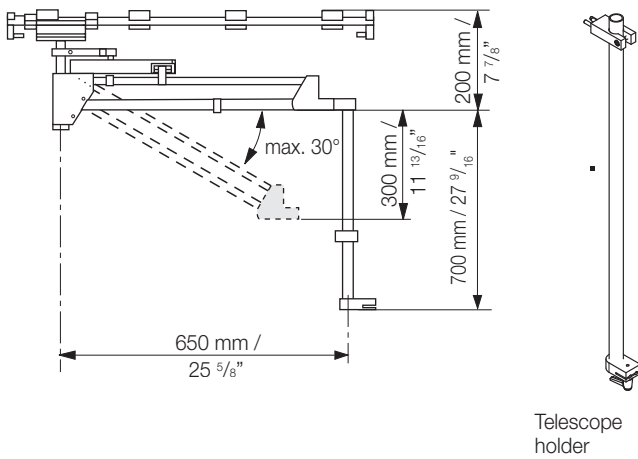

The rails are available in 1, 2 and 3 meter long pieces (3.3 ft., 6.6 ft. and 10 ft.). 3 meter long pieces (10 ft.) can be joined together. If the rails are installed high above the work station, the telescope holder should be used.

An angle larger than 60° between the rails and the parallelogram arm should be avoided, since it will result into sluggish positioning. Furthermore, it may also cause the guide carriage to move when reaching torque.

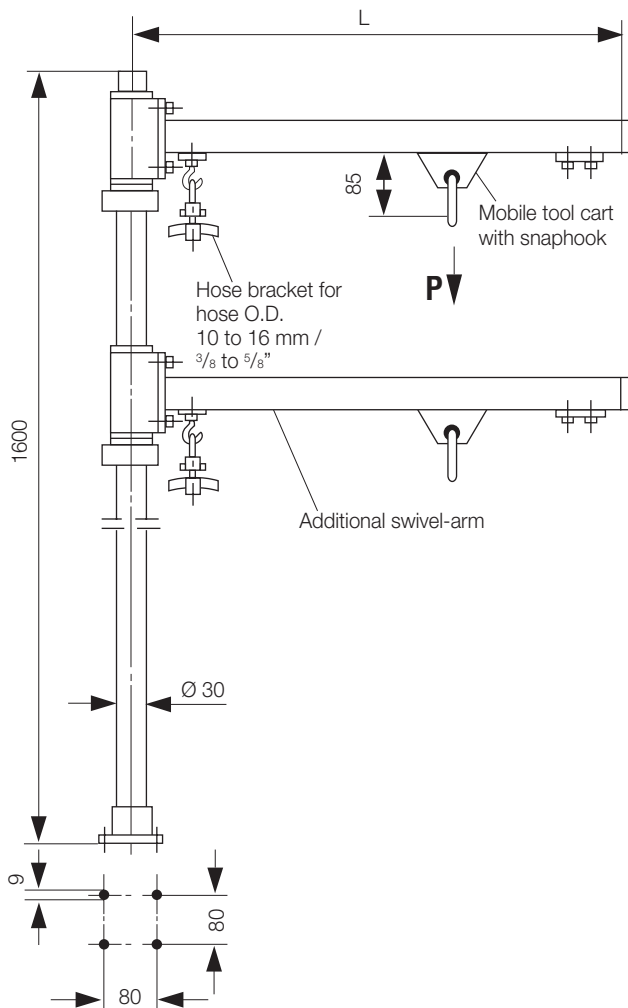

Swivel-arm for table installation

Track profile C-rail 30 x 32 mm

Length (L) mm/in.	Capacity (P) kg/lbs	Part no.
630 / 24.57	16 / 35.2	811600A
1000 / 39	10 / 22	811627A

Additional swivel-arm

Track profile C-rail 30 x 32 mm

Length (L) mm/in.	Capacity (P) kg/lbs	Part no.
630 / 24.57	16 / 35.2	811601A
1000 / 39	10 / 22	811630A

Swivel-arm for wall installation

Track profile C-rail 30 x 32 mm

Length (L) mm/in.	Capacity (P) kg/lbs	Part no.
630 / 24.57	20 / 44	811602A
1000 / 39	16 / 35.2	811731A

All swivel-arms are delivered with extended high arm tips. Through dismantling of a cone plate the arms can be set horizontally.

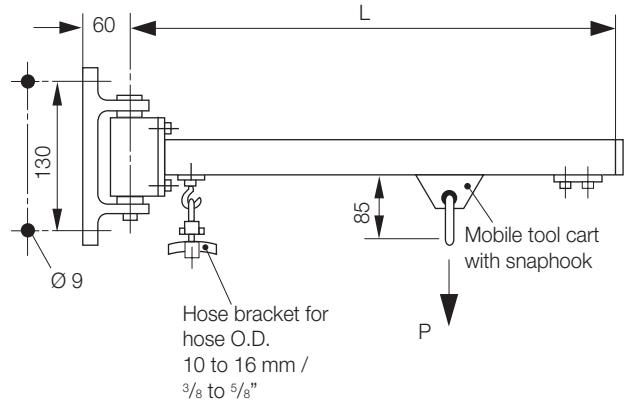

Balancer stand

for screwdriver straight (motor size 0)

Capacity kg/lbs	Working area mm/in.	Height mm/in.	Part no.
0.2-0.26/0.44-0.57	540-640 / 21-25	750 / 29.25	324348H
with maintenance unit and vacuum interruption for screw suction *)			
0.2-0.26/0.44-0.57	540-640 / 21-25	750 / 29.25	324348G
with maintenance unit, vacuum- and supply air interruption *)			
0.2-0.26/0.44-0.57	540-640 / 21-25	750 / 29.25	324348I

*) Injector is optional equipment

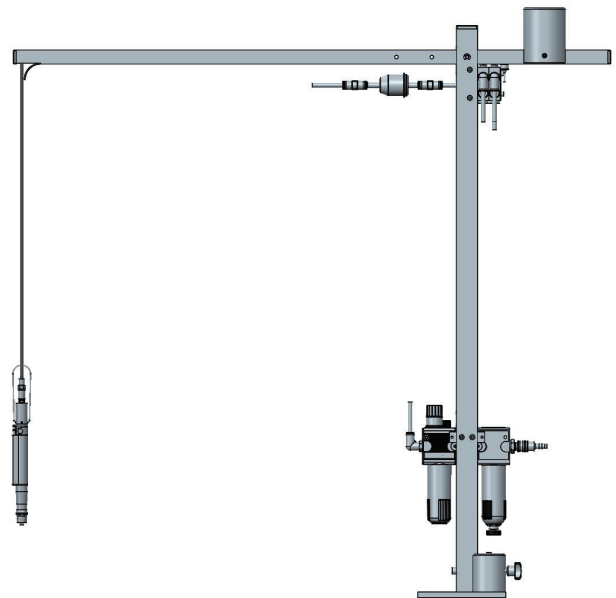

Telescopic torque arm

for screwdriver, straight

For torque reaction up to Nm/in.lbs	Working area mm/in.	Height max. mm/in.	Part no.	Weight kg/lbs
15 / 130	430- 925 / 16.77-36	-	408351A	1.14/2.5
22 / 195	540-1200 / 21 -46.8	-	408351B	1.6 /3.5

Required accessories:

Screwdriver adapter or V-mounting bracket (see pages 17/18). Please find suitable balancers on page 16.

Optional equipment:

Stand	400/15.6	408351C	1.3 /2.86
Clamping piece for pipe mounting (clamping range dia. 25 - 50 mm)	-	408351D	0.25/0.55

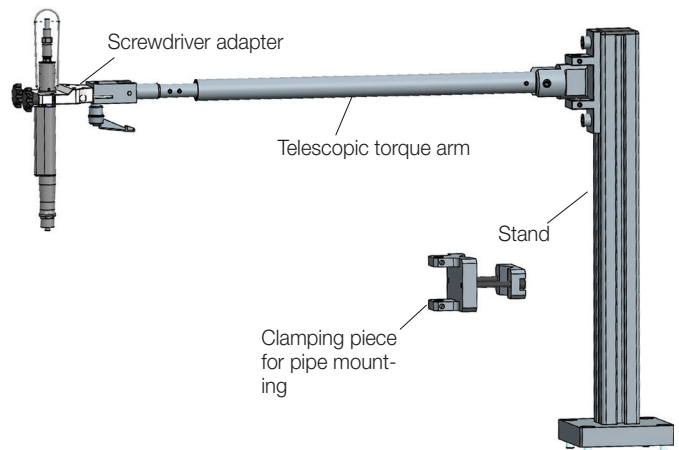

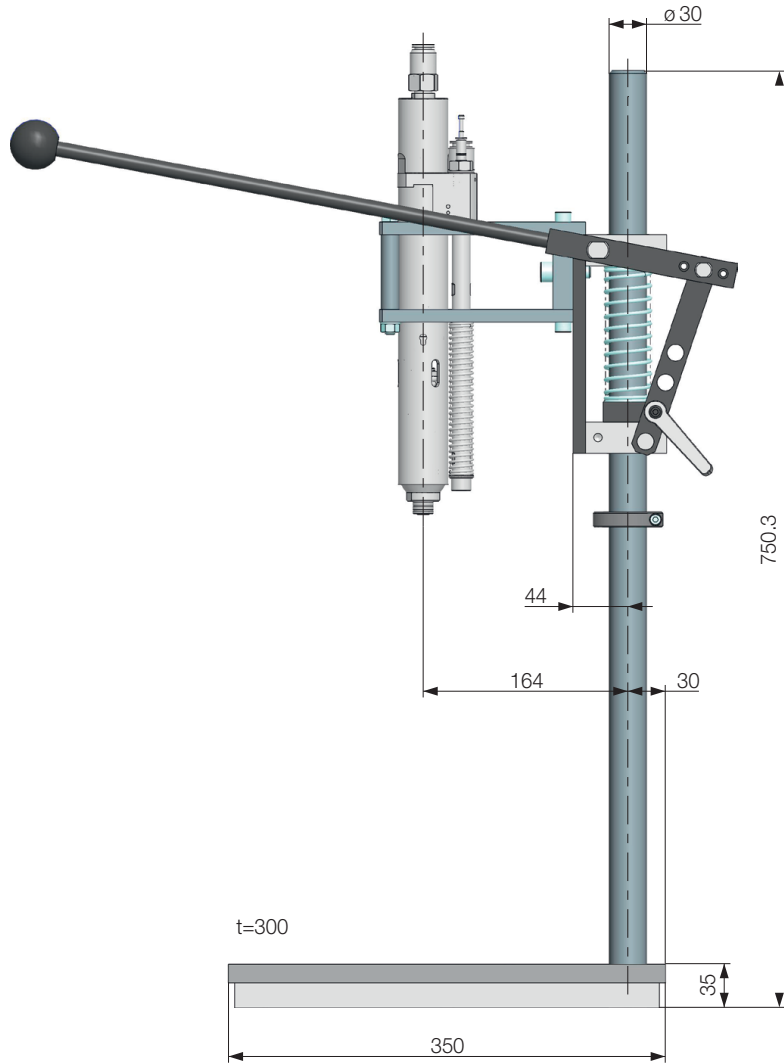

Screwdriver stand

Suitable for	Screwdriver right-/left rotation	Screwdriver reversible
stationary screwdriver spindles	Part no.	Part no.
	335100A	335100A
for this screwdriver adapter (without spindle mounting hole) for pneumatic screwdrivers		
Motor size 0	336080A	336080A
Motor size 1	336080A	336080A
Motor size 2, without and with offset gearing	336080C	336080C
Motor size 3, without and with reduction gearing	336080C	336080C
Motor size 4	336080C	336080C
for this screwdriver adapter (with 1 spindle mounting hole) for pneumatic screwdrivers		
Motor size 0	336081	336081
Motor size 1	340995	340995
Motor size 2, without and with offset gearing	3380031	3380031
Motor size 3, without and with reduction gearing	326851	333953
Motor size 4	395717	395717
for this screwdriver adapter (without spindle mounting hole) for electric screwdrivers		
Series 320E19-../320E22-..	336080A	336080A
Series 320E27-../321E27-..-HP	336080A	336080A
Series 320E36-../321E36-..	336080A	336080A
for this screwdriver adapter (with 1 spindle mounting hole) for electric screwdrivers		
Series 320E19-..	160135	
Series 320E22-..	340995	
Series 320E27-../321E27-..-HP	3380031	
Series 320E36-../321E36-..	326851	

*) Screwdriver adapter for other screwdriver sizes upon request

ACCESSORIES

Balancers

Capacity from - to kg/lbs	Max. cable travel m/ft.	Weight kg/lbs	Part no. with turnable snap hook	Part no. with holding plate for rigid mounting on the linear stand	Part no. position control stand
without vacuum interruption					
0 - 0.5 / 0 - 1.1	1.6 / 5.2	0.4 / 0.88	833320A	8333201A	8333202A
0.3 - 1.5 / 0.7 - 3.3		0.5 / 1.1	833320B	8333201B	8333202B
1.2 - 2.5 / 2.6 - 5.5		0.6 / 1.3	833320C	8333201C	8333202C
0.5 - 2 / 1.1 - 4.4	2.5 / 8.1	0.8 / 1.8	833390A	8333901A	8333902A
1.5 - 3 / 3.3 - 6.6		0.8 / 1.8	833390B	8333901B	8333902B
2 - 5 / 4.4 - 11		3.3 / 7.3	833395A	8333951A	8333952A
4 - 8 / 8.8 - 17.6	3 / 9.8	3.7 / 8.1	833395B	8333951B	8333952B
7 - 10 / 15.4 - 22		3.7 / 8.1	833395C	8333951C	8333952C
10 - 14 / 22 - 30.8		3.9 / 8.6	833395D	8333951D	8333952D
12 - 20 / 26.4 - 44	2 / 6.5	15.9 / 35	810350C	-	-
20 - 30 / 44 - 66		16.3 / 36	810351C	-	-
30 - 45 / 66 - 99		18 / 39.6	810352C	-	-
45 - 60 / 99 - 132		18.4 / 40.5	810353C	-	-
with vacuum interruption and integrated injector for screwdrivers with screw suction					
0 - 0.5 / 0 - 1.1	1.6 / 5.2	0.6 / 1.3	833402D	8334021D	8334022D
0.3 - 1.5 / 0.7 - 3.3			833402E	8334021E	8334022E
1.2 - 2.5 / 2.6 - 5.5			833402F	8334021F	8334022F
with conical rope barrel in order to balance the suspended load at any required pulling level					
0.4 - 1.2 / 0.88 - 2.6	1.5 / 4.9	1.3 / 2.9	828003A	-	-
1.2 - 2.6 / 2.6 - 5.7		1.4 / 3	828003B	-	-
2.6 - 3.8 / 5.7 - 8.4		1.5 / 3.3	828003C	-	-
3.8 - 5.2 / 8.4 - 11.4		1.5 / 3.3	828003D	-	-
5.2 - 6.5 / 11.4 - 14.3		1.5 / 3.3	828003E	-	-

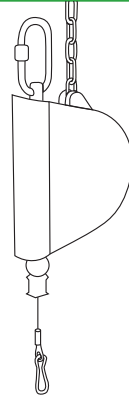

Hose balancers

Capacity from - to kg/lbs	Max. hose length m/ft.	Hose I.D. mm/in.	Air connection	Weight kg/lbs	Part no.
0.4 - 1.2 / 0.88 - 2.6	0.8 / 2.6	5 / 0.2	1/4" f / coupler 804251	1.2 / 2.6	824069A
1.2 - 2.2 / 2.6 - 4.8				1.3 / 2.86	824069B
2.2 - 3 / 4.8 - 6.6				1.4 / 3.08	824069C

With the DEPRAG balancers, tools, machines and parts can be suspended completely balanced, at any height and moved up and down effortlessly. The balancers are suspended in such a way that the required work height is within the available stroke height.

Spiral hoses - for balancers with vacuum interruption

Hose I.D. mm/in.	D mm/in.	L working area m/ft.	L fully extended max. m/ft.	Connection	Part no.
for supply air NANOMAT / MICROMAT screwdriver					
4 / 0.16	32 / 1.25	0.8 - 2 / 2.6 - 6.6	3 / 9.8	plug 801555/coupler 820301	346697D
for supply air MINIMAT screwdriver (motor size 1)					
4 / 0.16	32 / 1.25	0.8 - 2 / 2.6 - 6.6	3 / 9.8	plug 801555/coupler 820367	346697H
for supply air MINIMAT screwdriver (motor size 2)					
6 / 0.23	65 / 2.54	1 - 2.5 / 3.3 - 8.2	5 / 16.4	plug 323213/coupler 804282	346697K
vacuum hose with connection for injector (screwdriver motor sizes 00, 0, 1, 2, 2.5 and 3)					
4 / 0.16	32 / 1.25	0.8 - 2 / 2.6 - 6.6	3 / 9.8	plug 820366	346697J

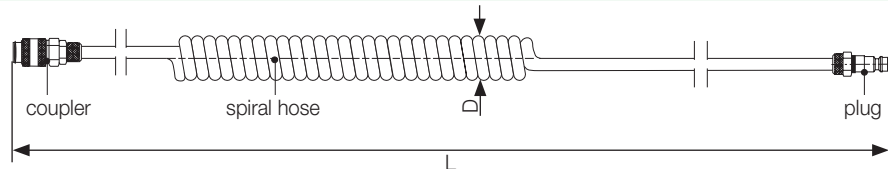

Please find further spiral hoses in our brochure D3340E on page 4.

Screwdriver adapter for electric screwdrivers

Suitable for screwdriver style	Series	Screwdriver adapter, not turnable - standard version, Part no.
EC screwdriver MINIMAT-EC, straight	320EGx22-../321EGx22-..	4008331U
	320EGx27-../ 321EGx27-..(-HP)	4008331U
	320EGA/EGT36-../321EGx36-..	118246B
EC screwdriver MINIMAT-EC, angle head design	320EWT27-../321EWT27-..	4008331V
	321EWT27-..-HP	400833W
	320EWT36-../321EWT36-..	400833W
Electric screwdriver, handheld, straight	342EGT-0003	4008330E
	342EGx-0012/..-0019	4008330B
	342EGx-0029/..-0049	4008330C
	342EGx-0088/..-0120	4008330D
Digital screwdriver MINIMAT-ED, straight	330EGx36-..	118246B
Suitable for screwdriver style	Series	Screwdriver adapter, turnable - standard version, Part no.
EC screwdriver MINIMAT-EC, straight	320EGA27-../321EGA27-..	367300E
	320EGA36-../321EGA36-..	367300D
EC screwdriver MINIMAT-EC, pistol grip	320EPT27-../321EPT27-..	367300A
	321EPT27-..-HP	367300F
	320EPT36-../321EPT36-..	367300F
Suitable for screwdriver style	Series	Screwdriver adapter, turnable - special version, Part no. for screwdrivers in conjunction with feeders only - in tight and badly accessible locations
EC screwdriver MINIMAT-EC, straight	320EGx27-../321EGx27-..	401014B

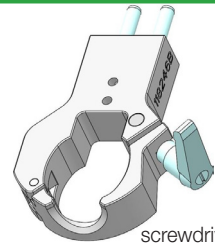

screwdriver adapter, part no. 118246B

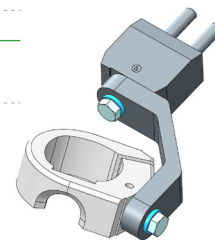

screwdriver adapter, part no. 367300D

Screwdriver adapter for pneumatic screwdrivers

Suitable for screwdriver style	Motor size	Screwdriver adapter, not turnable - standard version, Part no.
NANOMAT, straight, push-to-start	00	400833Y
MINIMAT, straight, push-to-start	1	4008331A
	2 and 2.5	400833B
	3	400833A
MINIMAT, straight, lever-start	2 / 2.5 / 3	400833C
MINIMAT, straight, remote-start	4 with off-set gear	400833K (Linearstativ 408010C)
	4 without off-set gear	922644
MINIMAT, angle head design	2	400833W
	2.5	4008331N
	3	400833N
	4	400833L
Suitable for screwdriver style	Motor size	Screwdriver adapter, turnable - standard version, Part no.
MINIMAT, straight	2	367300E
MINIMAT, pistol grip	2	367300A
	2.5	367300B
	3	367300C
Suitable for screwdriver style	Motor size	Screwdriver adapter, turnable - special version, Part no. for screwdrivers in conjunction with feeders only - in tight and badly accessible locations
MINIMAT	1	401014A
	2	401014B
	2.5	401014D
	3	401014C

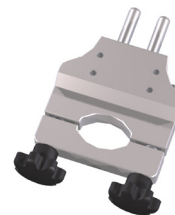



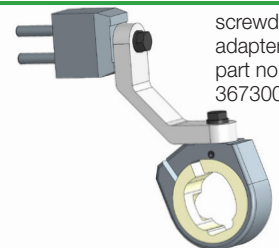

screwdriver adapter, part no. 400833Y

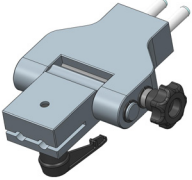

screwdriver adapter, part no. 367300E

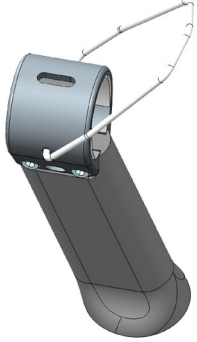
ACCESSORIES

Designation	Suitable for	Part no.	Picture
V-mounting bracket all-purpose applications	all tools upto a max torque of 1 Nm	4008331E	bracket range dia. 16.5-36 mm/0.64-1.4 in.
	all tools upto a max torque of 20 Nm	400833E	bracket range dia. 20 -54 mm/0.78-2.1 in.
	all tools upto a max torque of 40 Nm	4008331R	bracket range dia. 43 -64 mm/1.7 -2.5 in.
Adapter, turnable 45° and 90°	all screwdriver adapter (not for 400833K)	400833P	
Support ring	pneumatic screwdrivers, straight with push-to start (not for screwdrivers in conjunction with feeders) motor size 1 / motor size 2 / motor size 3	3870321 / 389775A / 398704A	
Pistol grip	MINIMAT-EC screwdriver, straight series 320EGA22-../321EGA22-.. 320EGA27-../321EGA27-../321EGZ27-..	4055451E 4055451E	
	series 320EGA36-..	4055452D	
	MINIMAT-ED screwdriver, straight series 330EG36-00..	4055452D	
	pneumatic screwdrivers, straight, in conjunction with feeder motor size 1 (ERGOMAT, type 347V-..)	4055451A 4055451I 4055452B 4055451C	
	pneumatic screwdrivers, straight (not suitable for ESD screwdriver, screwdriver in conjunction with feeder and screwdriver with lever-start) motor size 0 / motor size 1	833058 / 821702	
Handle	MINIMAT-EC screwdriver, straight series 320EGA36-../321EGx36-.. MINIMAT-ED screwdriver, straight series 330EG36-00..	415795	
	MINIMAT-EC screwdriver, pistol grip series 320EPT36-../321EPT36-..	4109711	
	pneumatic screwdrivers, straight motor size 1 (also in conjunction with feeder) motor size 2 motor size 2.5 motor size 2.5 in conjunction with feeder motor size 3	354660B 328536L 360749 3607491 328756A	
	pneumatic screwdrivers, pistol grip motor size 2.5 (also in conjunction with feeder) motor size 3 (also in conjunction with feeder) motor size 4	415438 4109711 4109711	

Stand-alone operation with DEPRAG sequence controller without toolbox

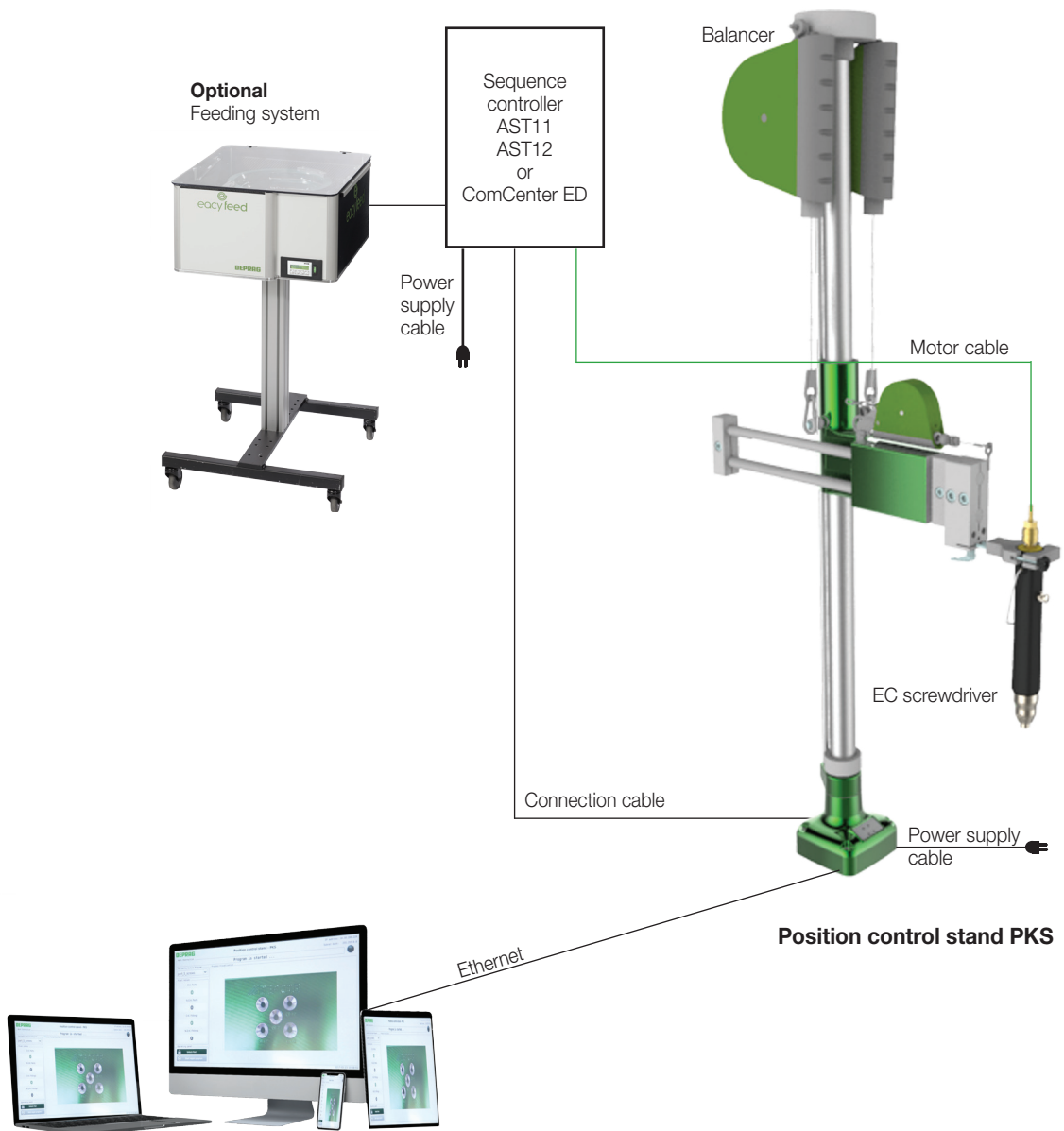

- Screw position evaluation: PKS
- Screwdriving program selection: PKS

Stand-alone operation with DEPRAG sequence controller and toolbox

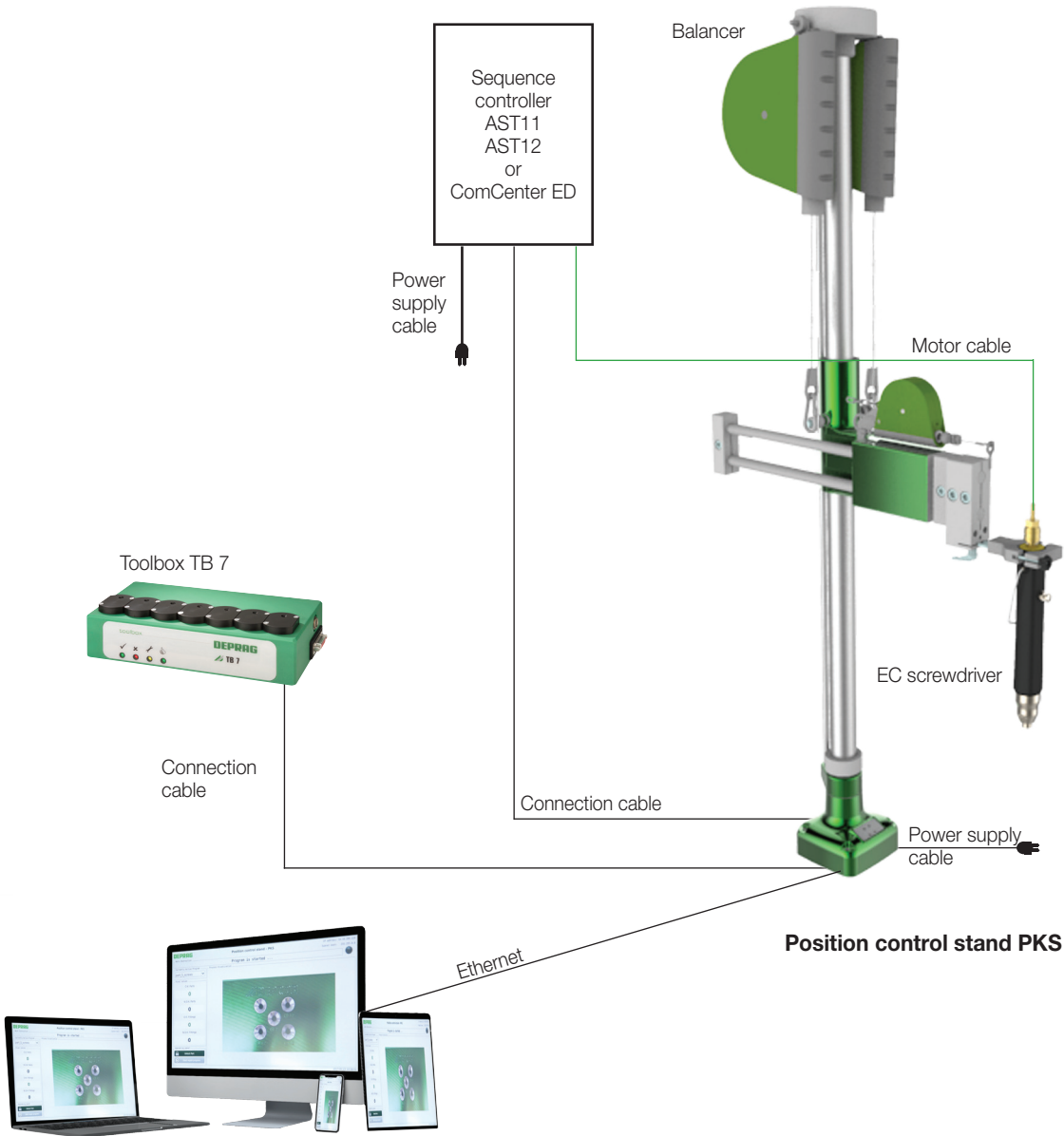

- Screw position evaluation: PKS
- Screwdriving program selection: PKS

Operation with external controller via input/output interface

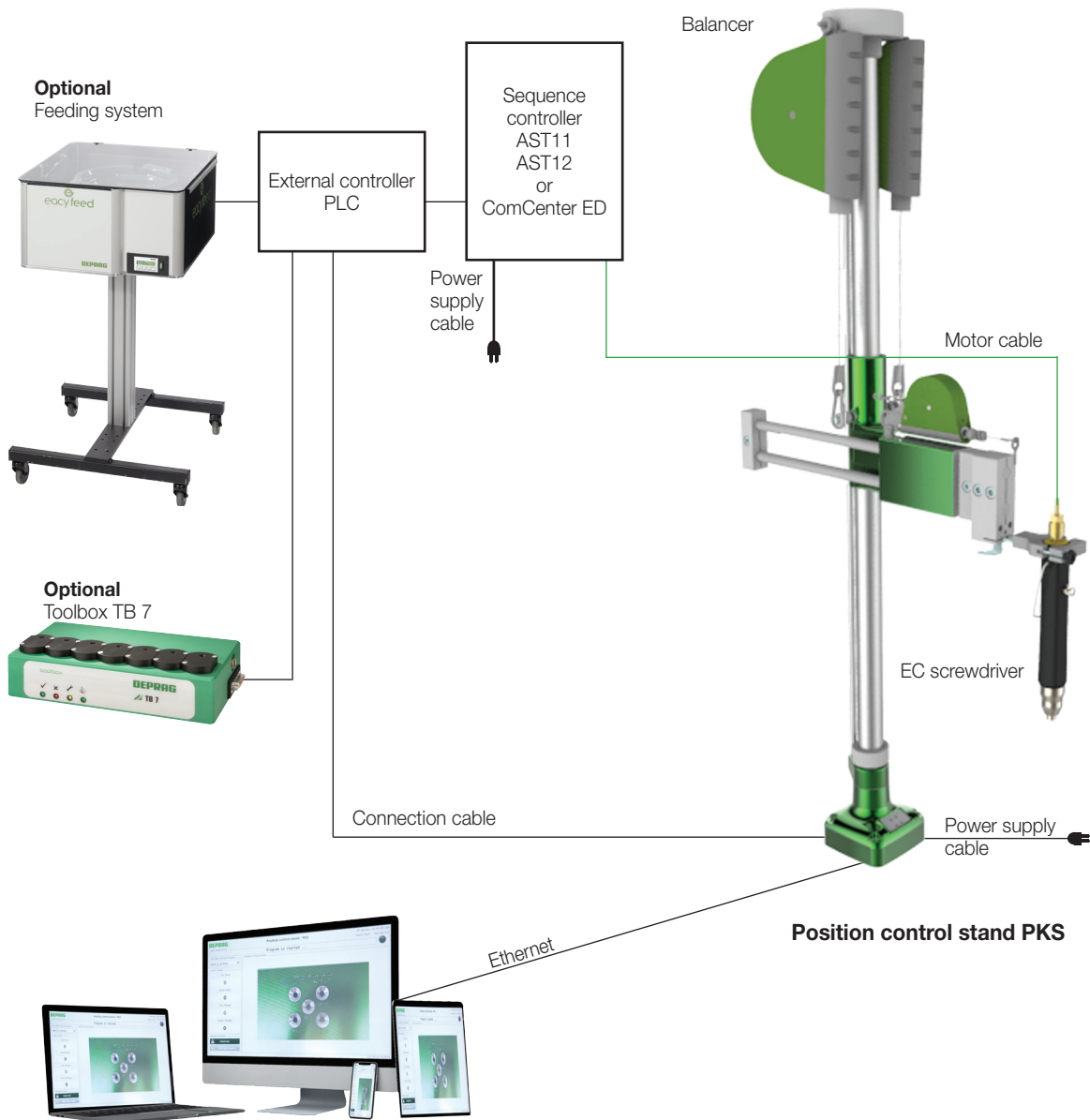

- Screw position evaluation: PKS
- Screwdriving program selection: PLC

Operation with external controller via fieldbus

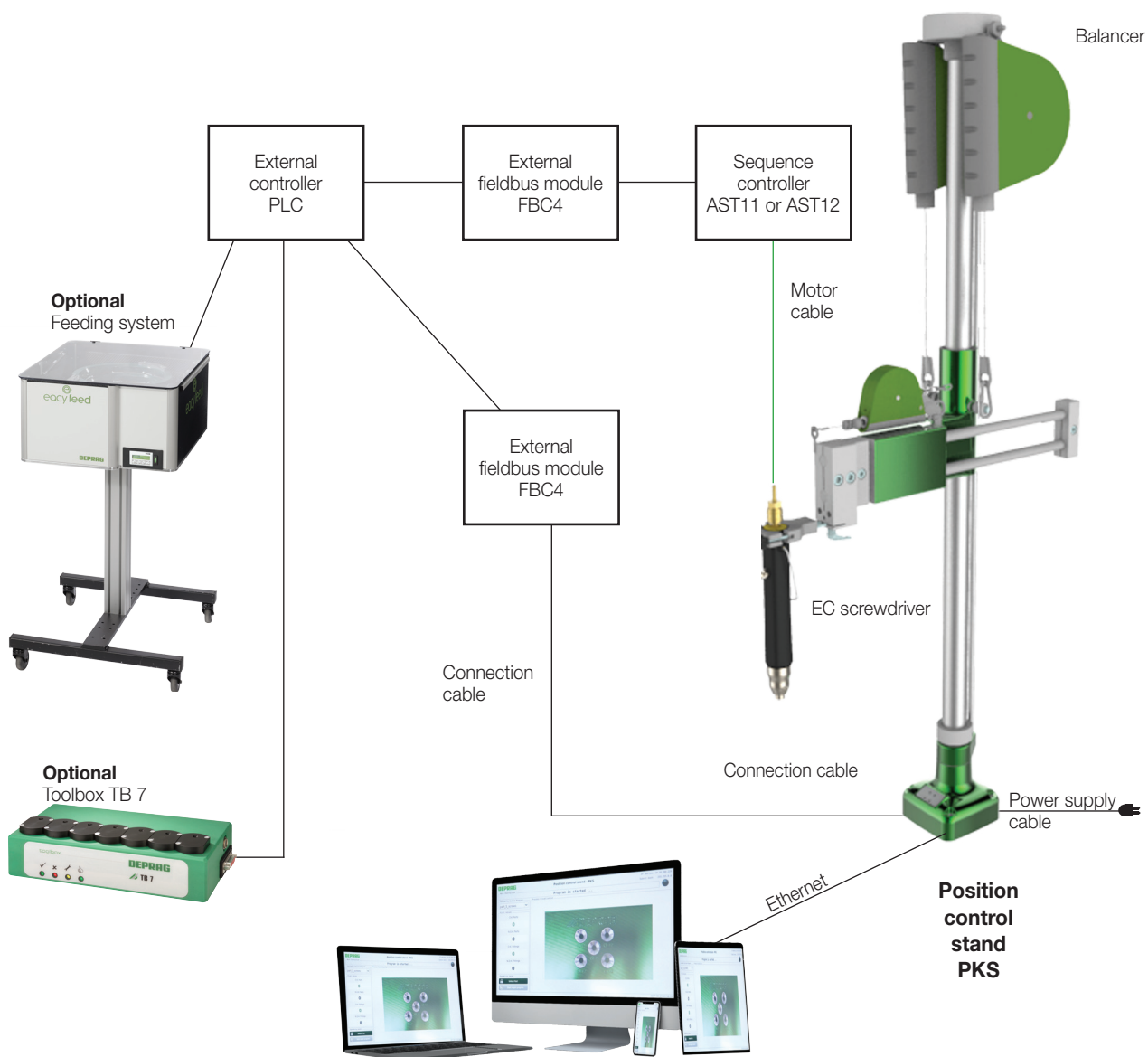

- Screw position evaluation: PLC
- Screwdriving program selection: PLC

Please consider both the weight of the horizontal arm and of the screwdriver in order to select the appropriate balancer. We highly recommend the use of two balancers to spread the total weight more evenly.

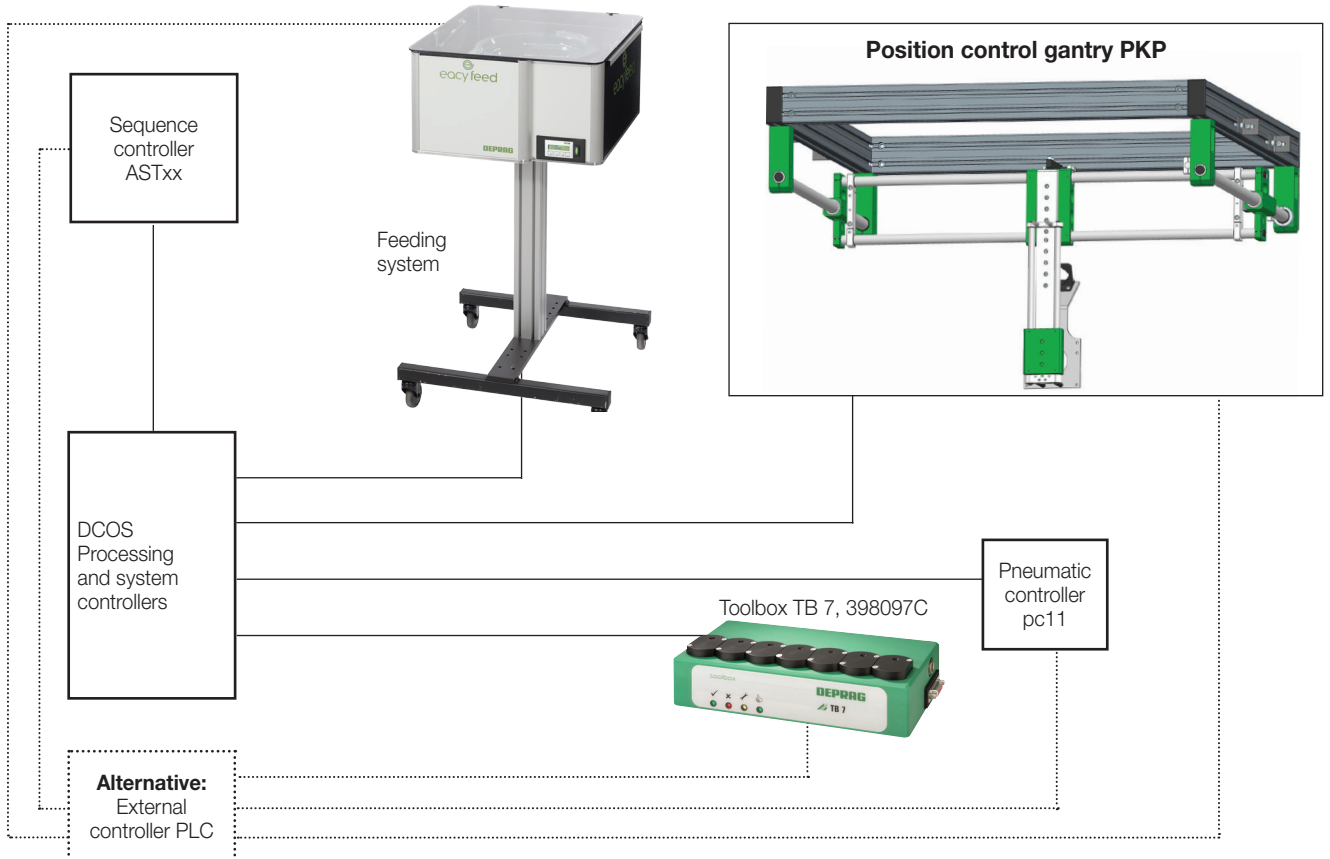

- The position control gantry functions via a processing and system controller (DCOS)
- A DCOS (DEPRAG Controller System) consists of
 - the control and operating unit (DPU)
 - the control cabinet (DSEC)
 - standardised software packages

Please consider both the weight of the Z axis and of the screwdriver in order to select the appropriate balancer. We highly recommend the use of two balancers to spread the total weight more evenly.

For the Netherlands:



DEPRAG

DEPRAG SCHULZ GMBH u. CO.
P.O. Box 1352, D-92203 Amberg, Germany
Carl-Schulz-Platz 1, D-92224 Amberg
Phone (+49) 9621 371-0, Fax (+49) 9621 371-120
www.deprag.com
info@deprag.de

CERTIFIED AS PER DIN EN ISO 9001